

IR-CA SERIES HIGH-SPEED RADIATION THERMOMETER



The IR-CA Product Line of Non-Contact Infrared Thermometers provides broad selection of units to match your applications and requirements for non-contact temperature measurement. The product line consists of 15 different Series grouped into General Purpose and Application Specific models.



■ General Purpose Models

<i>Low Temperature – Long Wavelength</i>	IR-CAB	IR-CAB Series measures temperatures as low as -50°C with an accuracy of $\pm 0.8^{\circ}\text{C}$.	Page 2
<i>Low Temperature – Short Wavelength</i>	IR-CAE	IR-CAE Series measures temperature as low as 30°C with a very fast response time of 20 milliseconds. Because it operates at a relatively short wavelength, this series is ideal for measuring low temperature, unoxidized metals.	Page 2 & 3
<i>Low to Medium Temperature and Small Spot Size</i>	IR-CAP	IR-CAP Series measures temperature as low as 80°C , with some models having measuring spot sizes as small as 1mm at a distance of 300mm. This series is ideal for measuring metals and measuring through quartz and glass windows.	Page 3
<i>Medium Temperature – Wide Temperature Range</i>	IR-CAI	IR-CAI Series measures temperature as low as 200°C , provides temperature spans as wide as 1300°C with ultra fast 3 millisecond response times.	Page 3
<i>High Temperature – Wide Temperature Range</i>	IR-CAS	IR-CAS Series measures temperature as low as 500°C , provides temperature spans as wide as 2400°C with ultra fast 3 millisecond response times.	Page 3
<i>Multi-Wavelength – Multi-Function</i>	IR-CAQ	IR-CAQ Series is a unique one of a kind IR thermometer that provides 5 Modes of operation (customer selectable). Two different (sets of wavelengths) "2 Color" modes and Three different (wavelength) "Single Color" modes.	Page 4
<i>World's Widest Temperature Range Infrared Thermometer</i>	IR-CAW	IR-CAW Series has an ultra wide temperature range of 20 to 3500°C in one single unit.	Page 4

■ Application specific models

<i>Polyester Film</i>	IR-CAN	IR-CAN Series is designed to measure polyester films as thin as $12.5\mu\text{m}$. This unit operates at a wavelength that matches the PET absorption band. Temperature measurement can be made without affect of thickness and/or color.	Page 6
<i>Polyethylene Film</i>	IR-CAM	IR-CAM Series is designed to measure polyethylene films as thin as $12.5\mu\text{m}$. This unit operates at a wavelength that matches the Carbon-Hydrogen absorption band. Temperature measurement can be made without affect of thickness and/or color.	Page 6
<i>Measurement Inside of Furnace</i>	IR-CAR	IR-CAR Series is designed to look through hot combustion gases inside of a furnace. Its operating wavelength also minimizes background interference from hotter furnace walls.	Page 6
<i>Glass Temperature</i>	IR-CAG	IR-CAG Series is designed to measure glass temperature. This unit utilizes a Thermoelectrically Cooled MCT IR Detector to provide a fast and stable temperature measurement.	Page 6
<i>Semicon/Silicon</i>	IR-CAT	IR-CAT Series is designed to measure low temperature of Silicon wafers without seeing through the substrate therefore eliminating the interference of heaters/blocks.	Page 6
<i>Semicon/InGaAs</i>	IR-CAU	IR-CAU Series is designed to measure low temperature of InGaAs wafers without seeing through the substrate therefore eliminating the interference of heaters/blocks.	Page 6
<i>Food Industry</i>	IR-CAFX0	IR-CAFX0 Series is designed to measure Pasteurization temperatures (60 to 100°C) in the food industry, with high-speed (10 milliseconds) and high accuracy.	Page 7
<i>Hot Metal Detector</i>	IR-CADAC01	IR-CADAC01 Series is a HMD that detects the presence of hot metal on a production line. An Open Collector output is turned ON when hot metal enters the optical sensing path and exceeds the preset threshold level.	Page 7

■ SPECIFICATIONS

Low temperature/long wavelength IR-CAB

Measuring system: Broadband radiation thermometer
 Element: PE
 Measuring wavelength: 8 to 13 μm
 Measuring range: -50 to 100°C or 200 to 1000°C
 Accuracy rating: ±0.8°C (-50 to 100°C)
 ±2°C (100 to 200°C)
 ±0.1% of measured value (200 to 1000°C)
 (at 1.0 and reference operating conditions)
 Repeatability: 0.2°C or less (-50 to 100°C)
 1°C or less (20 to 1000°C)
 Stability: Temperature drift Lower than 100°C ---
 0.05°C /°C
 100 to 700°C --- 0.05%/°C of measured value
 Higher than 700°C --- 0.025%/°C of measured value
 At EMC test environment... ±15% of measuring range
 Resolution: 0.1°C (-50 to 100°C)
 1°C (20 to 1000°C)
 Response time (95%): 2 sec (-50 to 100°C)
 0.2 sec (20 to 1000°C)
 Optics: Fixed focus lens type
 Sighting: Laser targeting without viewfinder
 Lens aperture: 15mm diameter
 Power consumption: Maximum 5VA
 (* The reference operating condition: 23°C ± 5°C, 35 to 75%RH)

Low temperature/short wavelength IR-CAE

Measuring system: Narrow-band radiation thermometer
 Element: PbSe
 Measuring wavelength: 4 μm
 Measuring range: 30 to 200°C
 Accuracy rating: ±2°C
 (at 1.0 and reference operating conditions)
 Repeatability: 0.5°C or less
 Stability: Temperature drift 0.15°C /°C
 At EMC test environment... ±10% of measuring range
 Resolution: 0.1°C
 Response time (95%): 0.02 sec
 Optics: Fixed focus lens type
 Sighting: Laser targeting without viewfinder
 Lense aperture: 15mm diameter
 Power consumption: Maximum 10VA
 (* The reference operating condition: 23°C /°C ± 5°C /°C, 35 to 75%RH)

Relation between measuring distance and diameter

Unit: mm

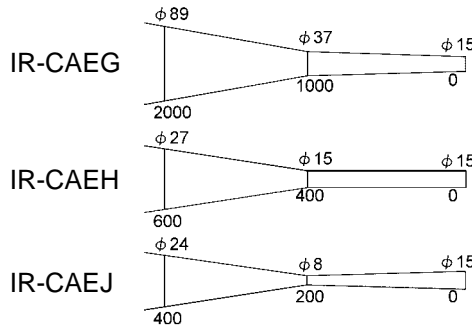

Relation between measuring distance and diameter

Measuring range: -50 to 100°C

Unit: mm

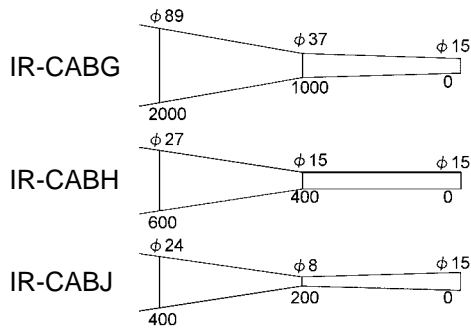

Measuring range: 20 to 1000°C

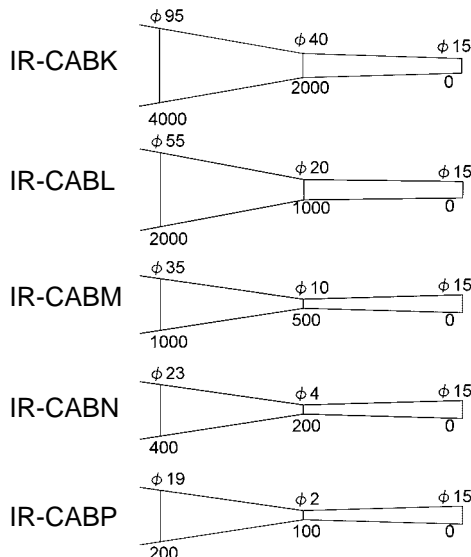

	Models	Measuring diameter/Measuring distance	Measuring range	Standard sighting
Low temperature /long wavelength	IR-CABG	37/1000mm	-50 to 100	Laser targeting (without view finder)
	IR-CABH	15/400mm		
	IR-CABJ	8/200mm		
	IR-CABK	40/2000mm	20 to 1000	
	IR-CABL	20/1000mm		
	IR-CABM	10/500mm		
	IR-CABN	4/200mm		
	IR-CABP	2/100mm		
IR-CABZ	Special	Ask CHINO		
Low temperature /short wavelength	IR-CAEG	37/1000mm	30 to 200	
	IR-CAEH	15/400mm		
	IR-CAEJ	8/200mm		
	IR-CAEZ	Special	Ask CHINO	

Connection
 ---C : Connector
 T : Terminal
 External input/output (option)
 N : None
 S : RS485
 5 : 4-20mA DC input
 J : Contact input (DI)
 K : Contact output (DO)

IR-CAB,IR-CAE

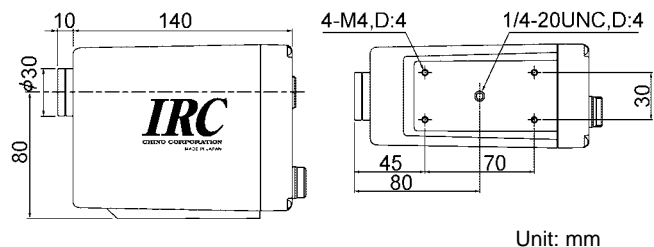

Unit: mm

Low temperature/short wavelength IR-CAE

Measuring system: Narrow-band radiation thermometer
 Element: PbSe
 Measuring wavelength: 4 μm
 Measuring range: 100 to 500°C (distance factor 200)
 Accuracy rating: ± 3°C
 (at 1.0 and reference operating conditions)
 Repeatability: 1°C or less
 Stability: Temperature drift 0.15°C/°C
 At EMC test environment... ± 10% of measuring range
 Resolution: 1°C
 Response time (95%): 0.02 sec
 Optics: Focusable lens type
 Sighting: Direct viewfinder
 Lens aperture: 20mm diameter
 Power consumption: Maximum 10VA
 (* The reference operating condition: 23°C ± 5°C, 35 to 75%RH)

Relation between measuring distance and diameter

Measuring distance: 0.5m to
 Measuring diameter: Measuring distance/distance factor

Distance factor	Measuring distance(mm)		
	500	1000	2000
200	2.5	5	10

Low to Medium temperature IR-CAP

Measuring system: Narrow-band radiation thermometer
 Element: PbS
 Measuring wavelength: 2 μm
 Measuring range: 80 to 250°C (distance factor 50)
 140 to 450°C (distance factor 200)
 200 to 800°C (distance factor 200 or 300)
 Accuracy rating: Lower than 500°C --- ± 3°C
 More than 500°C --- ± 5°C
 (at 1.0 and reference operating conditions)
 Repeatability: 1°C or less
 Stability: Temperature drift Lower than 500°C --- 0.15°C/°C
 Higher than 500°C --- 0.25%/°C
 At EMC test environment... ± 10% of measuring range
 Resolution: 1°C
 Response time (95%): 0.02 sec
 Optics: Focusable lens type
 Sighting: Direct viewfinder
 Lens aperture: 20mm diameter
 Power consumption: Maximum 10VA
 (* The reference operating condition: 23°C ± 5°C, 35 to 75%RH)

Relation between measuring distance and diameter

Measuring distance: 0.5m to
 Measuring diameter: Measuring distance/distance factor

Distance factor	Measuring distance(mm)		
	500	1000	2000
50	10	20	40
200	2.5	5	10
300	1.7	3.4	6.7

Medium temperature IR-CAI

Measuring system: Narrow-band radiation thermometer
 Element: InGaAs
 Measuring wavelength: 1.55 μm
 Measuring range: 200 to 1000°C (distance factor 50)
 300 to 1600°C (distance factor 200 or 300)
 400 to 2000°C (with field diaphragm 10, distance factor 200 or 300)
 Accuracy rating: Lower than 1000°C --- ± 5°C
 1000 to 1500°C --- ± 0.5% of measured value
 1500 to 2000°C --- ± 1% of measured value
 More than 2000°C --- ± 2% of measured value
 (at 1.0 and reference operating conditions)
 Repeatability: 0.2°C or less
 Temperature drift 0.1°C/°C or 0.015%/°C of measured value whichever larger.
 At EMC test environment... ± 1% of measuring range
 Resolution: 0.5°C
 Response time (95%): 0.003 sec
 Optics: Focusable lens type
 Sighting: Direct viewfinder
 Lens aperture: 20mm diameter
 Power consumption: Maximum 2.4VA
 (* The reference operating condition: 23°C ± 5°C, 35 to 75%RH)

Relation between measuring distance and diameter

Measuring distance: 0.5m to
 Measuring diameter: Measuring distance/distance factor

Distance factor	Measuring distance(mm)		
	500	1000	2000
50	10	20	40
200	2.5	5	10
300	1.7	3.4	6.7

(With field diaphragm 10)

Distance factor	Measuring distance(mm)		
	500	1000	2000
200	2.5	5	10
300	1.7	3.4	6.7

High temperature IR-CAS

Measuring system: Narrow-band radiation thermometer
 Element: Si
 Measuring wavelength: 0.9 μm
 Measuring range: 500 to 2000°C (distance factor 50)
 600 to 3000°C (distance factor 200 or 300)
 700 to 3500°C (with field diaphragm 10, distance factor 200 or 300)
 Accuracy rating: Lower than 1000°C --- ± 5°C
 1000 to 1500°C --- ± 0.5% of measured value
 1500 to 2000°C --- ± 1% of measured value
 More than 2000°C --- ± 2% of measured value
 (at 1.0 and reference operating conditions)
 Repeatability: 0.2°C or less
 Stability: Temperature drift 0.1°C/°C or 0.015%/°C of measured value whichever larger.
 At EMC test environment... ± 1% of measuring range
 Resolution: 0.5°C
 Response time (95%): 0.003 sec
 Optics: Focusable lens type
 Sighting: Direct viewfinder
 Lens aperture: 20mm diameter
 Power consumption: Maximum 2.4VA
 (* The reference operating condition: 23°C ± 5°C, 35 to 75%RH)

Relation between measuring distance and diameter

* Same as Medium Temperature Model IR-CAI

	Models	Distance factor	Measuring range
Low temperature/short wavelength	IR-CAE2	200	100 to 500
	IR-CAP0	50	80 to 250
Low to medium temperature	IR-CAP2	200	150 to 450 or 200 to 800
	IR-CAP3	300	200 to 800
	IR-CAI0	50	200 to 1000
Medium temperature	IR-CAI2	200	300 to 1600
	IR-CAI3	300	
	IR-CAI7	with field diaphragm 10, 200	400 to 2000
	IR-CAI8	with field diaphragm 10, 300	
High temperature	IR-CAS0	50	500 to 2000
	IR-CAS2	200	600 to 3000
	IR-CAS3	300	
	IR-CAS7	with field diaphragm 10, 200	700 to 3500
	IR-CAS8	with field diaphragm 10, 300	

- Connection
 - C : Connector
 - T : Terminal
- External input/output (option)
 - N : None
 - S : RS485
 - 5 : 4-20mA DC input
 - J : Contact input (DI)
 - K : Contact output (DO)
- Sighting
 - Blank : With view finder (standard)
 - 3 : Built-in 300mm close-up lens (option) (190-300mm measuring distance)
 - 6 : Built-in 600mm close-up lens (option) (270-600mm measuring distance)
 - L : Laser targeting (option) *without view finder

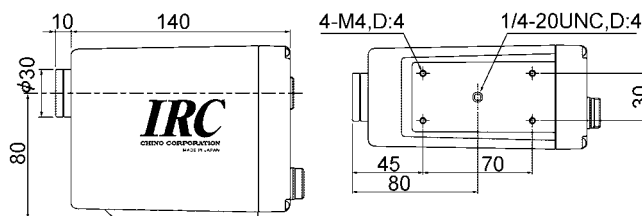

Unit: mm

Widest temperature IR-CAW

Measuring system: Broadband/Narrow-band radiation thermometer
 Element: TP/InGaAs/Si
 Measuring wavelength: 8-13/1.55/0.9 μm
 Measuring range: 20 to 3000°C
 Accuracy rating: Lower than 1000°C --- ±5°C
 1000 to 1500°C --- ±0.5% of measured value
 1500 to 2000°C --- ±1% of measured value
 More than 2000°C --- ±2% of measured value
 (at 1.0 and reference operating conditions)
 Repeatability: 1°C or less
 Stability: Temperature drift
 Lower than 1000°C --- 0.2°C/°C
 Higher than 1000°C --- 0.02%/°C of measured value
 At EMC test environment... ±1% of measuring range
 Resolution: 1°C
 Response time (95%): 0.1 sec
 Optics: Fixed focus lens type
 Sighting: Direct viewfinder
 Lens aperture: 30mm diameter
 Power consumption: Maximum 2.4VA
 (* The reference operating condition: 23°C ± 5°C, 35 to 75%RH)

Relation between measuring distance and diameter

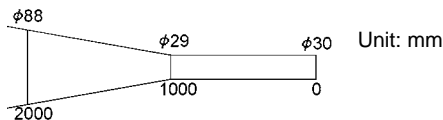

Models	Measuring diameter/Measuring distance	Measuring range	
IR-CAWV	29/1000mm	20 to 3000	with view finder
IR-CAWZ	Special	Ask CHINO	

- Connection
 - C : Connector
 - T : Terminal
- External input/output (option)
 - N : None
 - S : RS485
 - 5 : 4-20mA DC input
 - J : Contact input (DI)
 - K : Contact output (DO)
- Sighting
 - Blank: With view finder (standard)
 - L: Laser targeting (option)
 - *without view finder

IR-CAW

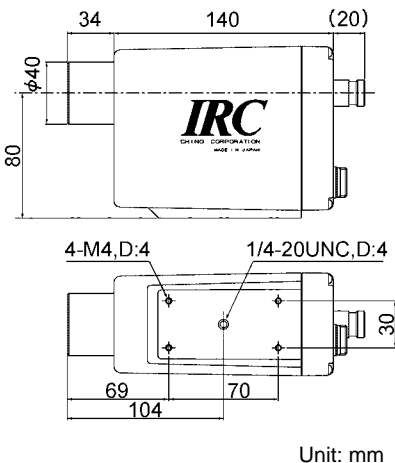

Multi-wave length/Multi-function IR-CAQ

Measuring system: Narrow-band radiation thermometer, single-two color selectable
 Element: InGaAs/InGaAs/Si
 Measuring wavelength: 1.55/1.35/0.9 μm
 Measuring range: 350 to 2000°C (distance factor 50)
 400 to 3100°C (distance factor 200 or 300)
 500 to 3500°C (with field diaphragm 10, distance factor 200 or 300)
 Accuracy rating: Lower than 1000°C --- ±5°C
 1000 to 1500°C --- ±0.5% of measured value
 1500 to 2000°C --- ±1% of measured value
 More than 2000°C --- ±2% of measured value
 (at 1.0 and reference operating conditions)
 Repeatability: 0.2°C or less
 Stability: Temperature drift 0.2°C/°C or 0.02%/°C of measured value whichever larger.
 At EMC test environment... ±1% of measuring range
 Resolution: 1.0°C
 Response time (95%): 0.02 sec
 Emissivity ratio setting: 1.9999 to 0.050
 Optics: Focusable lens type
 Sighting: Direct viewfinder
 Lens aperture: 20mm diameter
 Power consumption: Max 2.4VA
 (* The reference operating condition: 23°C ± 5°C, 35 to 75%RH)

Relation between measuring distance and diameter

Measuring distance: 0.5m to
 Measuring diameter: Measuring distance/distance factor

Distance factor	Measuring distance(mm)		
	500	1000	2000
50	10	20	40
200	2.5	5	10
300	1.7	3.4	6.7

(with field diaphragm 10)

Distance factor	Measuring distance(mm)		
	500	1000	2000
200	2.5	5	10
300	1.7	3.4	6.7

Models	Distance factor	Measuring range
IR-CAQ0	50	350 to 2000
IR-CAQ2	200	400 to 3100
IR-CAQ3	300	
IR-CAQ7	with field diaphragm 10, 200	500 to 3500
IR-CAQ8	with field diaphragm 10, 300	

- Connection
 - C : Connector
 - T : Terminal
- External input/output (option)
 - N : None
 - S : RS485
 - 5 : 4-20mA DC input
 - J : Contact input (DI)
 - K : Contact output (DO)
- Sighting
 - Blank: With view finder (standard)
 - 3 : Built-in 300mm close-up lens (option) (190-300mm measuring distance)
 - 6 : Built-in 600mm close-up lens (option) (270-600mm measuring distance)
 - L : Laser targeting (option)
 - *without view finder

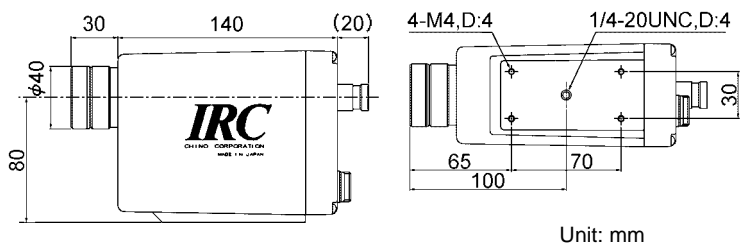

COMMON SPECIFICATIONS

Display	Temperature & parameter --- 4-digit LCD Unit --- °C or °F (Key switchable)
Emissivity setting	1.9999 to 0.050
Signal modulation	DELAY --- First-order lag (Time constant: 0.0 to 99.9 sec with 0.1 sec increment or 0.00 to 9.99 sec with 0.01 sec increment) Real signal must be set at 0 sec. PEAK --- Peak tracing (attenuation factor 0, 2, 5, 10°C/sec selectable) Peak hold must be set at 0°C.
Computation function	ZERO/SPAN adjustment, automatic emissivity computation, output correction
Analog output	4 to 20mA DC isolated output Load resistance: Less than 500 Accuracy rating: ± 0.2% of output range Resolution: 0.04% of output range Scaling: Programmable in measuring range Dummy output: Programmable within 0 to 100% of analog output
Parameter setting key	Operator mode --- Emissivity, signal modulation, alarm, others Engineering mode --- Measuring unit, output scaling, ZERO/SPAN, reference temperature for automatic emissivity computation, output correction and other options.
Self-diagnostic	Thermometer temperature abnormal, parameter error
Working temperature	0 to 50°C
Power supply	24V DC (allowable voltage fluctuation 22 to 28V DC) Recommended power supply unit IR-ZFEP (S82K-01524) IR-GZ IR-GC
Connections	Terminal or connector
Casing	Aluminum
Weight	Approx 1.3Kg
CE marking (connector connection only)	EMC directive EN61326+A1 Emission class A Immunity Annex A * The product complies when in use of exclusive power supply unit and connecting cable upto 30m. (* The reference operating condition: 23°C ± 5°C, 35 to 75%RH)

OPTIONS

Option	Contents
Communications interface*	RS485: Sending of measuring data, and sending/receiving of parameters
Analog output*	4-20mA input signal: Selection of emissivity remote setting or automatic emissivity computation
Contact input*	1 point: Peak hold reset or sample hold. Dry contact or open collector
Contact output*	1 point: High(low) alarm or error signal. Photo coupler 30VDC 50mA max
Laser targeting	Built-in semiconductor laser emitter. 1mW or lower (645nm), class2. No viewfinder model.

* Only one kind of option to be selected.



CAUTIONS FOR LASER TARGETING MODELS
 - Laser may damage your eyes. Don't stare into a laser beam.
 - Make sure to prevent from the reflection when you want to measure an object equivalent to mirror surface like a brilliant metal.

SETTING/DISPLAY PART

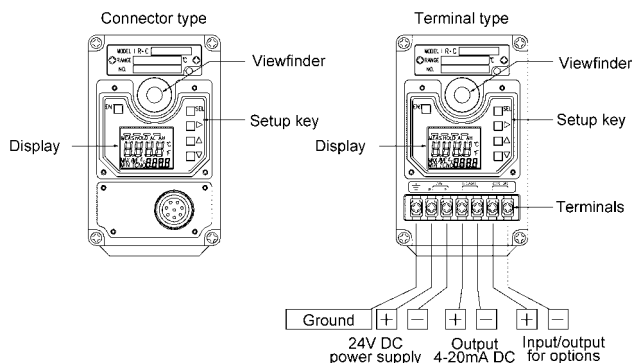

CONNECTIVITY

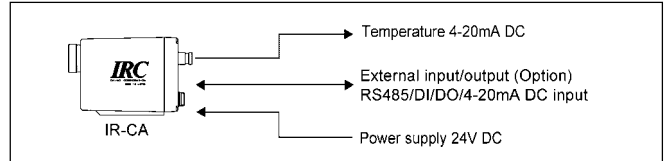

Remote setup system

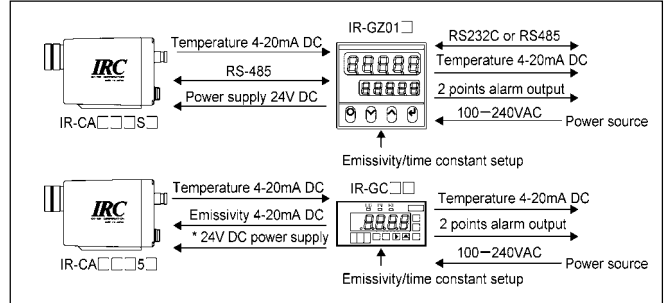

* Only IR-CAI/CAS/CAQ/CAW can be connected.
 Separate DC power supply is required for other models.

Data Acquisition Software (option)

This PC software records measuring data for the IR-CA.

Model

IR-VXC1
 J: Japanese
 E: English

Specifications

Environment	OS	Windows95/98/2000/XP
	Harddrive	20MB or more
	Memory	16MB or more
	Drive	Floppy disk drive
Function	Measuring data display Data storing, replay, print 1-3 units connectable	
Measuring mode	Realtime trend mode	

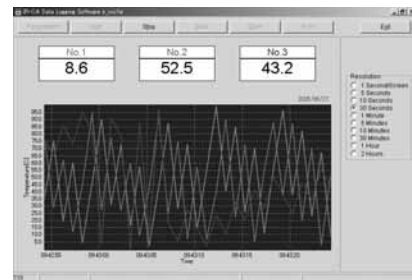

Connectivity

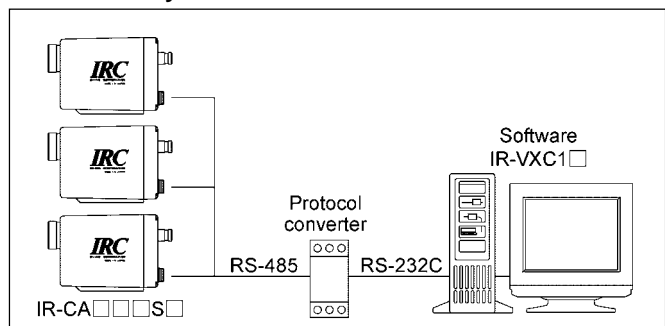

SPECIFICATIONS

Film Temperature IR-CAN , CAM

Measuring system: Narrow-band radiation thermometer
 Element: IR-CAN ---PE
 IR-CAM ---PbSe
 Measuring wavelength: IR-CAN --- 8 μm
 IR-CAM --- 3.43 μm
 Measuring range: IR-CAN ---0 to 300°C
 IR-CAM ---30 to 300°C
 Accuracy rating: Lower than 200°C --- ± 2°C
 More than 200°C --- ± 0.1% of measured value
 (at 1.0 and reference operating conditions)
 Repeatability: 1°C or less
 Stability: Temperature drift 0.15°C /°C
 At EMC test environment...IR-CAN: ± 15% of measuring range
 IR-CAM: ± 10% of measuring range
 Resolution: 1°C
 Response time (95%): 1 sec
 Optics: Fixed focus lens type
 Sighting: Laser spot without viewfinder
 Lens aperture: 15mm diameter
 Power consumption: IR-CAN --- Maximum 5VA
 IR-CAM --- Maximum 10VA
 (* The reference operating condition: 23°C ± 5°C, 35 to 75%RH)

Semiconductor IR-CAT , IR-CAU

Measuring system: Narrow-band radiation thermometer
 Element: Si
 Measuring wavelength: IR-CAT --- 0.6 to 0.96 μm
 IR-CAU --- 0.6 to 0.9 μm
 Measuring range: IR-CAT --- 400 to 800°C (distance factor 100)
 500 to 1000°C (distance factor 200)
 600 to 1200°C (distance factor 200)
 IR-CAU --- 400 to 800°C (distance factor 100)
 500 to 1000°C (distance factor 200)
 (at 1.0 and reference operating conditions)
 Accuracy rating: Lower than 600°C --- ± 3°C
 More than 600°C --- ± 0.5% of measured value
 Repeatability: 0.5°C or less
 Stability: Temperature drift
 Lower than 700°C ---0.1°C /°C
 More than 700°C --- 0.015%/°C of measured value
 At EMC test environment... ± 10% of measuring range
 Resolution: 0.5°C
 Response time (95%): 0.04 sec
 Optics: Focusable lens type
 Sighting: Direct viewfinder
 Lens aperture: 20mm diameter
 Power consumption: Maximum 10VA
 (* The reference operating condition: 23°C ± 5°C, 35 to 75%RH)

Relation between measuring distance and diameter

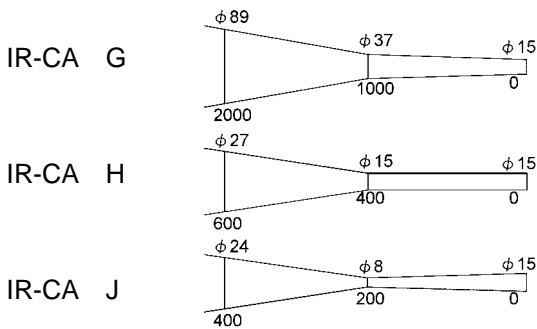

Relation between measuring distance and diameter

Measuring distance: 0.5m to
 Measuring diameter: Measuring distance/distance factor

Distance factor	Measuring distance(mm)		
	500	1000	2000
100	5	10	20
200	2.5	5	10

Measurement Inside Furnace object IR-CAR

Measuring system: Narrow-band radiation thermometer
 Element: PbSe
 Measuring wavelength: 3.8 μm
 Measuring range: 350 to 1100°C (distance factor 100)
 450 to 1300°C (distance factor 200)
 500 to 1500°C (distance factor 200)
 Accuracy rating: Lower than 1000°C --- ± 5°C
 More than 1000°C --- ± 0.5% of measured value
 (at 1.0 and reference operating conditions)
 Repeatability: 1°C or less
 Stability: Temperature drift
 Lower than 1000°C ---0.2°C /°C
 More than 1000°C --- 0.02%/°C of measured value
 At EMC test environment... ± 10% of measuring range
 Resolution: 1°C
 Response time (95%): 0.02 sec
 Optics: Focusable lens type
 Sighting: Direct viewfinder
 Lens aperture: 20mm diameter
 Power consumption: Maximum 10VA
 (* The reference operating condition: 23°C ± 5°C, 35 to 75%RH)

Glass Temperature IR-CAG

Measuring system: Narrow-band radiation thermometer
 Element: MCT
 Measuring wavelength: 5 μm
 Measuring range: 100 to 800°C (distance factor 50)
 200 to 1800°C (distance factor 100)
 400 to 2800°C (distance factor 200)
 Accuracy rating: Lower than 1000°C --- ± 5°C
 1000 to 1500°C --- ± 0.5% of measured value
 1500 to 2000°C --- ± 1% of measured value
 More than 2000°C --- ± 2% of measured value
 (at 1.0 and reference operating conditions)
 Repeatability: 1°C or less
 Temperature drift: Lower than 1000°C --- 0.2°C /°C
 More than 1000°C --- 0.02%/°C of measured value
 Resolution: 1°C
 Response time (95%): 0.1 sec
 Optics: Focusable lens type
 Sighting: Direct viewfinder
 Lens aperture: 20mm diameter
 Power consumption: Maximum 10VA
 (* The reference operating condition: 23°C ± 5°C, 35 to 75%RH)

Relation between measuring distance and diameter

Measuring distance: 0.5m to
 Measuring diameter: Measuring distance/distance factor

Distance factor	Measuring distance(mm)		
	500	1000	2000
50	10	20	40
100	5	10	20
200	2.5	5	10

Relation between measuring distance and diameter

Measuring distance: 0.5m to
 Measuring diameter: Measuring distance/distance factor

Distance factor	Measuring distance(mm)		
	500	1000	2000
100	5	10	20
200	2.5	5	10

Food industry IR-CAF_{X0} (non-CE approval)

Measuring system: Narrow-band radiation thermometer
 Element: PbSe
 Measuring wavelength: 4 μm
 Measuring range: 60 to 100°C
 Accuracy rating: 70 to 90°C --- ± 1.0°C
 Except 70 to 90°C --- ± 2°C
 (at 1.0 and reference operating conditions)
 Repeatability: 0.3°C
 Temperature drift: 0.04°C /°C
 Resolution: 0.2°C
 Response time (95%): 0.01 sec
 Optics: Fixed focus lens type
 Sighting: Laser targeting without viewfinder
 Lens aperture: 15mm diameter
 Power consumption: Maximum 10VA
 (* The reference operating condition: 23°C ± 5°C, 35 to 75%RH)

Relation between measuring distance and diameter

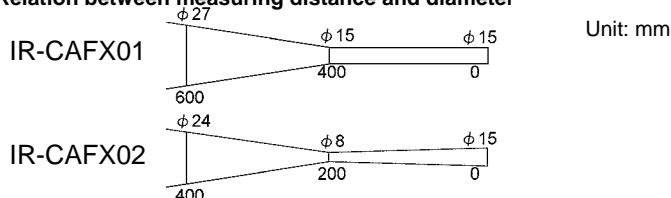

Models

Polyester film

Models	Measuring diameter/Measuring distance	Measuring range	Standard sighting
IR-CANG	37/1000mm	0 to 300	Laser targeting (without viewfinder)
IR-CANH	15/400mm		
IR-CANJ	8/200mm		
IR-CANZ	Special (Ask CHINO)		

Polyethylene film

Models	Measuring diameter/Measuring distance	Measuring range	Standard sighting
IR-CAMG	37/1000mm	30 to 300	Laser targeting (without viewfinder)
IR-CAMH	15/400mm		
IR-CAMJ	8/200mm		
IR-CAMZ	Special (Ask CHINO)		

Connection
 --- C: Connector
 --- T: Terminal
 External input/output (option)
 --- N: None
 S: RS485
 5: 4-20mA DC input
 J: Contact input (DI)
 K: Contact output (DO)

Intrafurnace object

Models	Distance factor	Measuring range	Standard sighting
IR-CAR1	100	350 to 1100	Direct viewfinder
IR-CAR2	200	450 to 1300	
IR-CAR2		500 to 1500	

Glass

Models	Distance factor	Measuring range	Standard sighting
IR-CAG0	50	100 to 800	Direct viewfinder
IR-CAG1	100	200 to 1800	
IR-CAG2	200	400 to 2800	

Semiconductor/Silicon

Models	Distance factor	Measuring range	Standard sighting
IR-CAT1	100	400 to 800	Direct viewfinder
IR-CAT2	200	500 to 1000	
IR-CAT2		600 to 1200	

Semiconductor/InGaAs

Models	Distance factor	Measuring range	Standard sighting
IR-CAU1	100	400 to 800	Direct viewfinder
IR-CAU2	200	500 to 1000	

Connection
 --- C: Connector
 --- T: Terminal
 External input/output (option)
 --- N: None
 S: RS485
 5: 4-20mA DC input
 J: Contact input (DI)
 K: Contact output (DO)
 Sighting
 --- Blank: With view finder (standard)
 --- L: Laser targeting (option) *without view finder

EXTERNAL DIMENSIONS

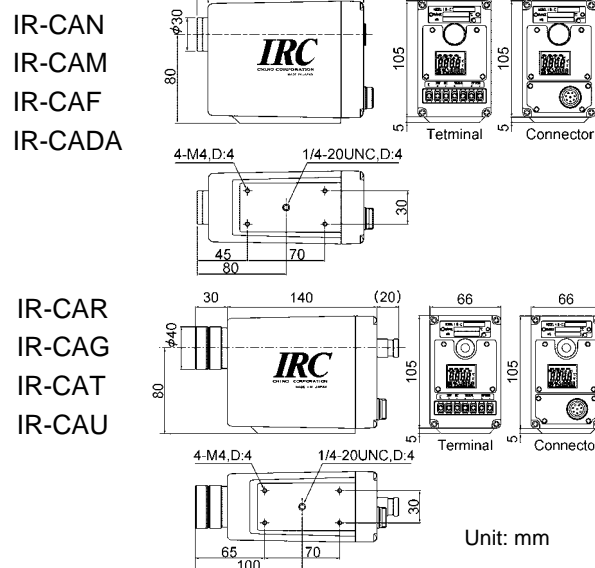

HMD (Hot Metal Detector) IR-CADAC01 (non-CE approval)

Output is turned ON when hot metal enters the optical sensing path and exceeds the preset threshold level.



Features

- Detect luminance temperature of 100 to 550°C or equivalent.
- Remote object detection
- External detect level setup by 4-20mA DC

Model

IR-CADAC01

Connectivity

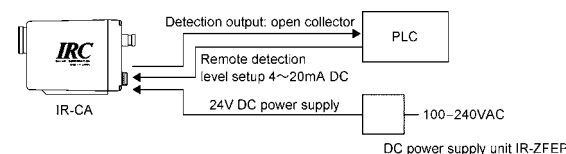

Specifications

Detection system	Radiation luminance threshold judgement
Detection	Luminance temperature of 100 to 550°C or equivalent
Response time	0.1 sec
Output	Open collector, normally OFF
Detection level	Built-in trimmer or external 4-20mA DC
Optics	Fixed focus lens type
Measuring spot size	150mm/15m
Targeting	Direct viewfinder (reverse view)
Working temperature	0 to 50°C
Power supply	24V DC (22-28V DC)
Accessory	Airpurg hood (sold separately)

SETTING DISPLAY UNIT IR-GZ



Setting display unit IR-GZ

Wall-mount box IR-ZGBW

The IR-GZ is combined with the IR-CA with optional RS485, programs parameters, displays measuring data and supplies 24V DC power to the IR-CA.

Connectivity

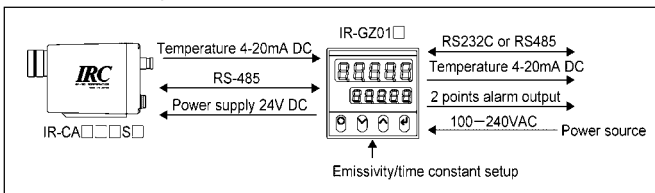

Model

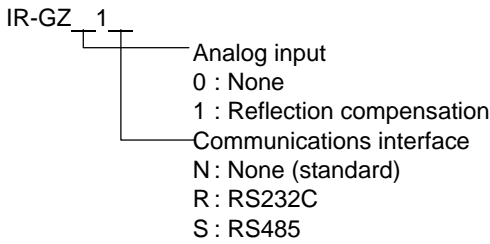

SPECIFICATIONS

Emissivity (ratio) setting:	1.999 to 0.050
Thermometer input:	RS485
Signal modulation:	DELAY --- First-order lag (Time constant: 0.0 to 99.9 sec with 0.1 sec increment or 0.00 to 9.99 sec with 0.01 sec increment) Real signal must be set at 0 sec. PEAK --- Peak tracing (attenuation factor 0, 2, 5, 10°C /sec selectable) Peak hold must be set at 0°C.
Reflection compensation:	Reflection source temperature PT100 /4 to 20mA/IR-thermometer (Keypad selectable)
Display:	Temperature, Thermometer number being connected, Status display
Analog output:	Output 1: 4 to 20mA DC IR-GZ output (Load resistance: less than 500 Ω) Output 2: 4 to 20mA DC IR-CA output (Load resistance: less than 500 Ω)
Output renewal cycle:	Output 1: 100ms Output 2: Depending on the model of IR-CA
Output accuracy ratings:	Output 1: ±0.2% of output range Output 2: ±0.2% of output range Stability at EMC test environment... ±1%
Event output:	2 points Select 2 points within "High temperature alarm", "High-high temperature alarm", "Low temperature alarm" and "Low-low temperature alarm". Relay a-contact Contact capacity 240V AC 1.5A 30V DC 1.5A

Communications interface:	RS232C (Optional) or RS485 (Optional)
Connectable number of IR-CA:	Maximum 31 units
Power supply to IR-CA:	24V DC 0.45A (Number of connectable IR-CA depends on the model.)
Power supply:	100 to 240V AC, 50/60Hz
Power consumption:	Maximum 20VA
Working temperature:	-10 to 50°C
Working humidity:	20 to 90%RH (No dew condensation)
Casing:	Nonflammable Polycarbonate
Installation:	Panel mount type
Weight:	Approx 0.5Kg
	EMC directive EN61326+A1
	Low voltage EN61010-1+A2
	Overvoltage category II,
	Pollution level 2

External dimensions

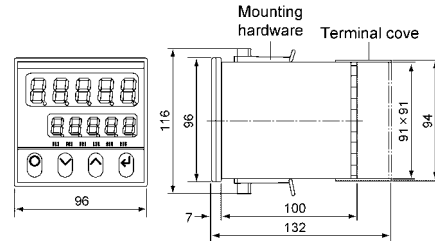

Panel cutout

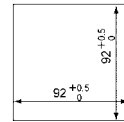

Wall-mount box IR-ZGBW (Purchase IR-GZ separately)

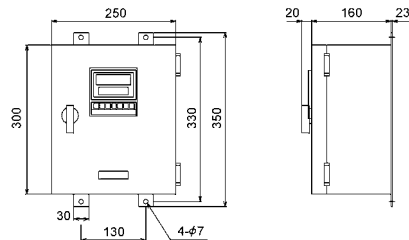

Unit: mm

Terminal diagrams

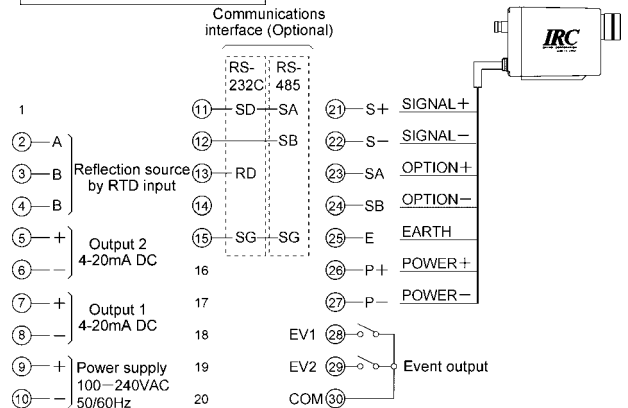
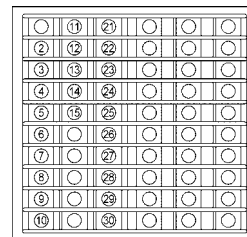

INDICATOR WITH POWER SUPPLY IR-GC



The IR-GC is combined with the IR-CA, setup emissivity, displays measuring data and supplies 24V DC power to the IR-CA.

Connectivity

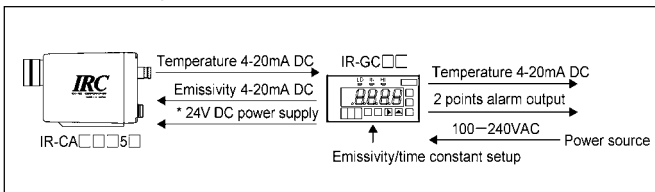

* Only IR-CAI/CAS/CAQ/CAW can be connected.
Separate DC power supply is required for other models.

Model

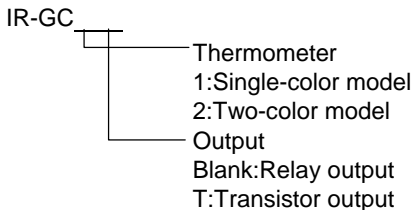

External dimensions

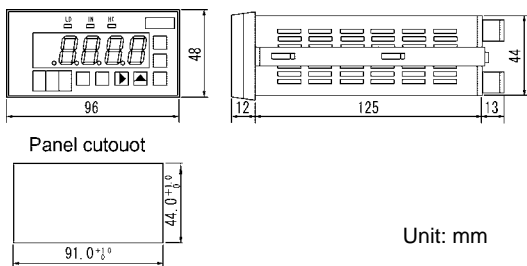

Terminal diagrams

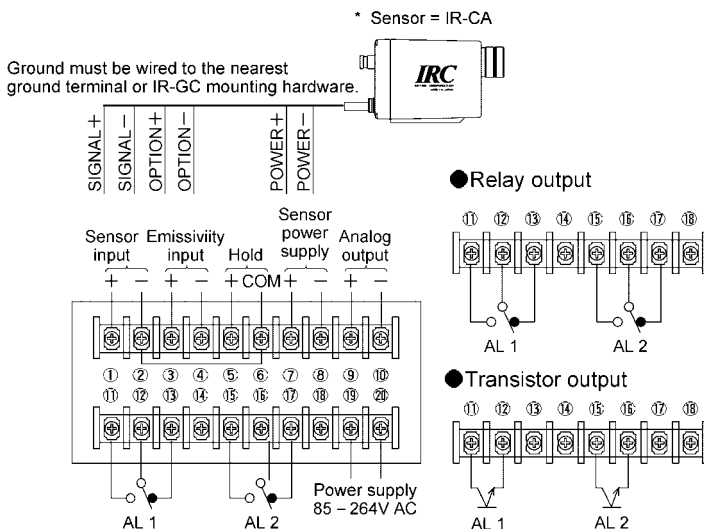

SPECIFICATIONS

Emissivity (ratio) setting:	Single-color model: 2.000 to 0.001 (0.001 increment) Two-color model: 1.250 to 0.750 (0.001 increment)
Emissivity (ratio) setting signal:	4 to 20mA DC
Input signal:	4 to 20mA DC (thermometer output), Input resistance 50
Input sampling cycle:	8 to 206ms
Modulator:	Select from 9 kinds of set value Averaging --- Tracing of average value between sections Hold --- Output hold by holding signal (external a contact) Sampling hold, peak hold, bottom hold
Display:	Data, mode, alarm status
Analog output:	4 to 20mA DC isolated output, Load resistance: lower than 750
Output renewal cycle:	16 to 214ms (depending on input sampling time)
Accuracy rating:	Display accuracy --- $\pm 0.1\%$ of scaling range ± 1 digit Analog output accuracy --- $\pm 0.2\%$ of scaling range $\pm 1^\circ\text{C}$
Alarm outputs:	High and low independent setup, Relay output or transistor output Relay output (1ab) Contact capacity 125VA (250V AC), 60VA (30V DC) Transistor output (Open collector) Rated load voltage 24V DC Max load current 50mA Response time --- 11 to 209ms (depending on input sampling time)
Dummy output:	4 to 20mA DC Front key setup
Output correction:	Broken line setting
Power supply to thermometer:	24V DC 0.1A * Models being supplied from IR-GC IR-CAI, IR-CAS, IR-CAQ, IR-CAW * Separate DC power supply unit is required for other models.
Power supply:	100 to 240V AC, 50/60Hz
Power consumption:	Approx 20VA
Working temperature:	0 to 50°C
Working humidity:	Lower than 90%RH (no dew condensation)
Weight:	Approx 0.4Kg

Airpurge Hood IR-ZCAP (for IR-ZCCH)

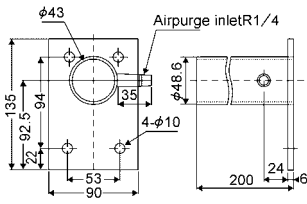

The airpurge hood is used to disperse dust and fume for keeping the light path. It is mounted to the front of the hard protective case IR-ZCCH . Use clean dried air.

Front water-cooling plate IR-ZCWC (for IR-ZCCH)

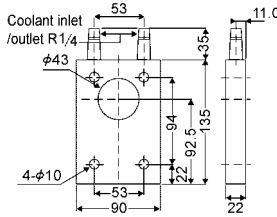

The front water-cooling plate is used when installing the thermometer under high ambient temperature. It is mounted to the front of the hard protective case IR-ZCCH . It is applicable when the thermal radiation is intense from the front.

Flange mounting unit IR-ZCAF (for IR-ZCCH)

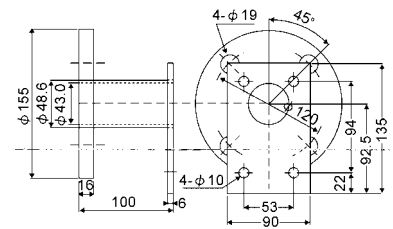

The flange mounting unit is used for fixing at the front of hard protective case IR-VCCH . It is also applicable for mounting the IR-VSW and IR-ZW .

Water-cooling flange IR-VSW

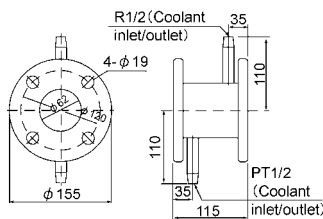

Sealing window IR-ZW

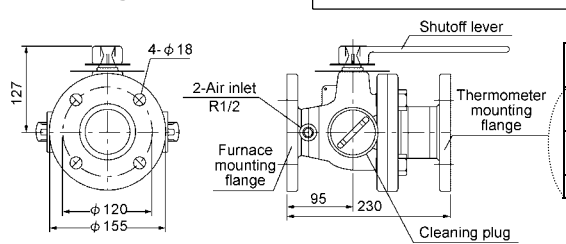

	Window material	Applicable model
0	Quartz	IR-CAI,IR-CAS,IR-CAQ,IR-CAP,IR-CAU,IR-CAT
1	CaF2	IR-CAE,IR-CAG,IR-CAR,IR-CAN,IR-CAM
2	BaF2	IR-CAB,IR-CAW

Connecting cable

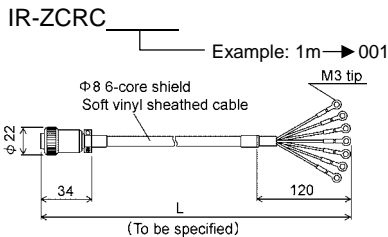

Close-up lens IR-VAD (for focusable model)

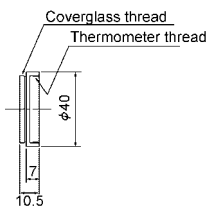

Models	Measuring distance	Applicable model
IR-VAD30A	190 to 300 mm	IR-CAI,IR-CAS,IR-CAQ,IR-CAP,IR-CAU,IR-CAT
IR-VAD30G	190 to 300 mm	IR-CAE(Focusable model), IR-CAG,IR-CAR
IR-VAD60A	270 to 600 mm	IR-CAI,IR-CAS,IR-CAQ,IR-CAP,IR-CAU,IR-CAT
IR-VAD60G	270 to 600 mm	IR-CAE(Focusable model), IR-CAG,IR-CAR

IR-ZCRT

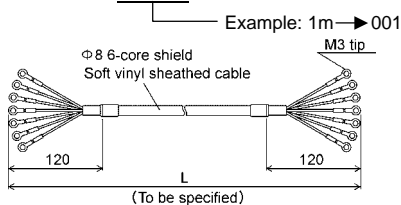

Mirror IR-ZCLM

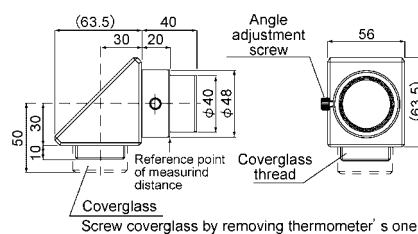

Eyepiece filter IR-ZCLF

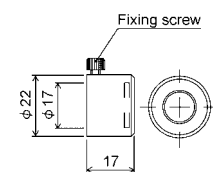

IR-ZCRL

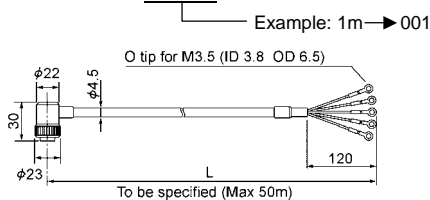

Angle finder IR-ZCLA

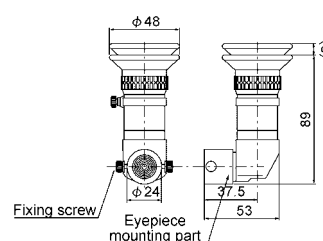

Tripod IR-ZBMT

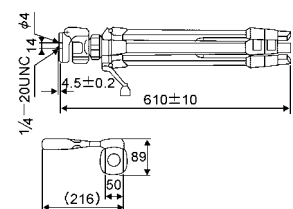

Universal Head

Simple type IR-VMS

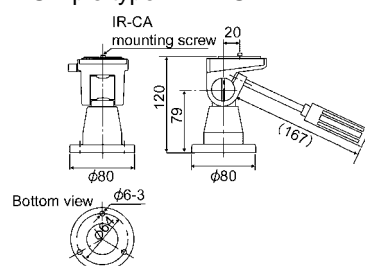

Soft type IR-ZMS

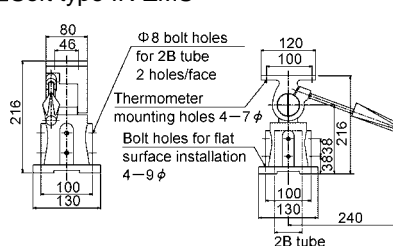

Hard type IR-VMH

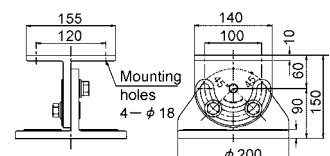

Specifications subject to change without notice. Printed in Japan (I) 2005. 7 Recycled Paper

CHINO CORPORATION

32-8, KUMANO-CHO, ITABASHI-KU, TOKYO 173-8632
PHONE: +81-3-3956-2171
FAX: +81-3-3956-0915
E-mail: inter@chino.co.jp
Website: <http://www.chino.co.jp>



mawi-therm
Temperatur-Prozess-technik GmbH
Hofstraße 23 • D-40789 Monheim
phone +49 2173 51094
fax +49 2173 58623
e-mail info@mawi-therm.com